



Depicted rubber buffers are available optionally.



Available in explosion proof version (please see page 452).

## Hand chain hoist with integrated push or geared type trolley model Yalelift IT

Capacity 500 - 20000 kg

The combination of the Yalelift 360 with a low headroom manual trolley provides even more flexibility in the application of the Yalelift 360.

### Features

- All units of this series up to a capacity of 3000 kg are provided with single chain fall and the min. headroom (Dim. A) has been further reduced. Ideal for applications with low ceilings and limited headroom.
- The proven and almost stepless adjustment system allows quick and easy assembly of the trolley.
- Trolleys up to 5 t are offered for two beam ranges. Range A for a flange width up to 180 mm is standard and covers approx. 80 % of all applications. Conversion to range B for beam width up to 300 mm can be easily accomplished.
- The trolley wheels are designed for a max. beam profile incline of 14 % (DIN 1025 - part 1), excellent rolling features are guaranteed by prelubricated, encapsulated ball bearings.
- Anti-drop and anti-tilt devices as standard.

### Options

- Adjustable overload protection device.
- Chain container
- Rubber buffers
- Corrosion resistant version
- Beam locking device to secure the unloaded trolley in a fixed position on the beam (park position e.g. on ships). Available up to a capacity of 5000 kg.

Technical data model Yalelift ITP/G

Model	EAN-No. 4025092*	Capacity in kg/ number of chain falls	Size	Beam flange width b	Beam flange thickness t max.	Curve radius min.	Weight at standard lift (3 m) - P	Weight at standard lift (3 m) - G	Weight at standard lift (3 m) with locking device - P kg	Weight at standard lift (3 m) with locking device - G kg
				mm	mm	m	kg	kg		
YLIT 500	*288255	500/1	A	50 - 180	19	0.9	20	24	26	31
YLIT 500	-	500/1	B	180 - 300	19	0.9	21	25	27	32
YLIT 1000	*292221	1000/1	A	50 - 180	19	0.9	27	32	35	40
YLIT 1000	-	1000/1	B	180 - 300	19	0.9	29	33	37	41
YLIT 2000	*291798	2000/1	A	58 - 180	19	1.15	44	49	52	57
YLIT 2000	-	2000/1	B	180 - 300	19	1.15	46	50	54	58
YLIT 3000	*291804	3000/1	A	74 - 180	27	1.5	77	82	86	91
YLIT 3000	-	3000/1	B	180 - 300	27	1.4	79	84	88	93
YLIT 5000	*291828	5000/2	A	98 - 180	27	2.0	125	130	135	140
YLIT 5000	-	5000/2	B	180 - 300	27	1.8	129	134	139	144
YLIT 10000	*080996	10000/3	B	125 - 310	40	1.8	-	202	-	212
YLIT 20000 <sup>1</sup>	*172325	20000/6	B	180 - 310	40	9.5	-	on request	-	on request

<sup>1</sup> Dimensions on request

P in connection with weight = with push trolley      G in connection with weight = with geared trolley



Chain guide



High quality encapsulated ball bearings and sliding bushes for smooth and effortless operation.



The robust stamped steel housing with four stay bolts is resistant to the toughest working conditions.



The precisely machined load sheave ensures accurate movement of the load chain.

## INFO

Yale hoists and trolleys are not designed for passenger elevation applications and must not be used for this purpose.

# Hoisting Equipment Hand chain hoists

## Dimensions model Yalelift IT

Model	YLIT 500	YLIT 1000	YLIT 2000	YLIT 3000	YLIT 5000	YLIT 10000
A min., mm	245	272	323	382	550	784
A1, mm	158	178	205.5	252	260.5	380
A2, mm	-	-	-	-	-	-
B, mm	17	22	30	38	45	68
C, mm	24	29	35	40	47	68
D, mm	14	19	22	30	37	50
F (Geared trolley), mm	92	92	91	107	149.5	113
H1, mm	24.5	24	23.5	32	30.5	55
I (Push trolley), mm	71.5	71.5	95.5	131	142.5	169
I (Geared trolley), mm	76.5	76.5	98	132.5	148.5	169
L, mm	270	310	360	445	525	430
L1, mm	130	130	150	180	209	200
L2, mm	159	175	207	256	283	261
L3, mm	-	-	-	-	-	-
L4, mm	-	-	-	-	-	-
M, mm	M 18	M 22	M 27	M 30	M 42	M 48
O, mm	60	60	80	112	125	150
P (Geared trolley), mm	108	110	112	112	117	158
T (Area A), mm	280	290	305	320	364	-
T (Area B), mm	400	410	425	440	484	540

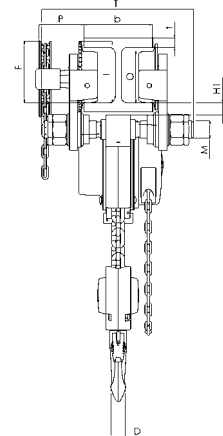
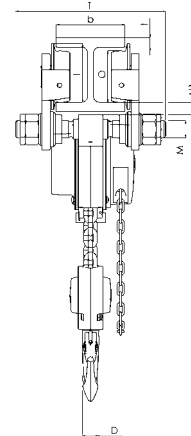
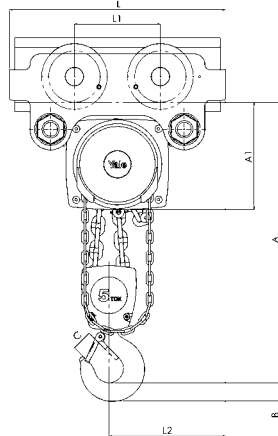
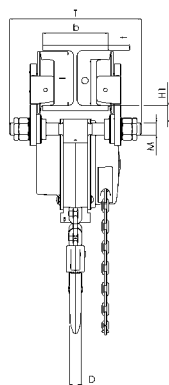
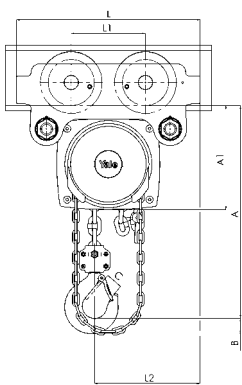

Model Yalelift ITP, 500 - 3000 kg, single fall

Model Yalelift ITP/ITG, 5000 kg, double fall

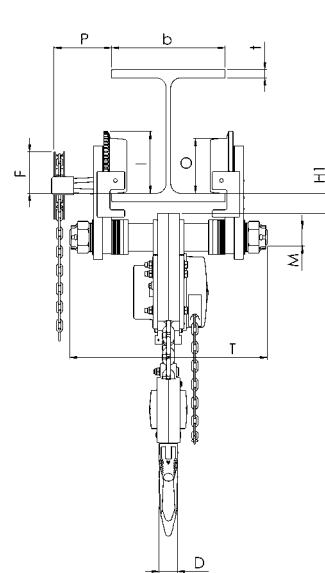
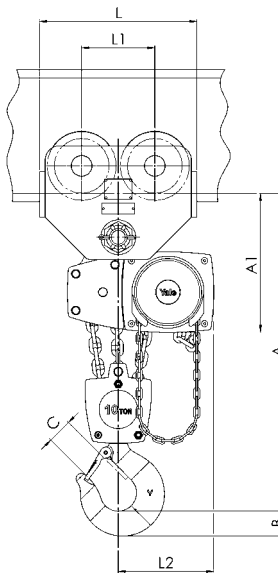
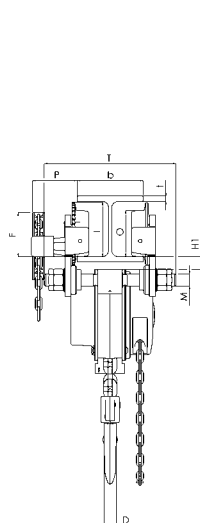
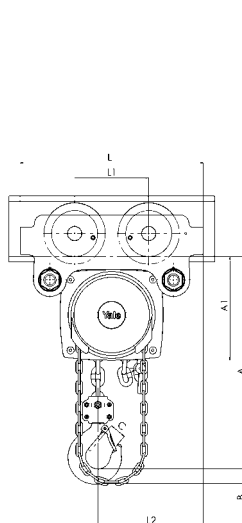

Model Yalelift ITG, 500 - 3000 kg, single fall

Model Yalelift ITG, 10000 kg, three fall