



Yale **ERGO 360[®] UT** *Utility!*

Ratchet lever hoist with safety gear

Capacity 1500 - 9000 kg

The Yale **ERGO 360[®] UT** is now also redefining the world of hoists for overhead line construction. The automatically acting safety gear, with a pending patent, once more increases the safety of use.

Here, too, the ergonomic and safety enhancing design of the device and the revolutionary, patented hand lever enable efficient work at any angle, for lifting and pulling applications.

Features

AUTOMATICALLY ACTING SAFETY GEAR

The Yale **ERGO 360[®] UT** has a unique, automatically locking safety device to prevent a sudden drop (patent pending). It guarantees permanent monitoring and is active during operation as well as during inactive moments without the user having to activate it.

In case of emergency, i.e. after failure of the load pressure brake and consequently exceeding the specified speed, the safety gear will automatically activate.

It safely absorbs the load, preventing the creation of larger dynamic forces which could cause further damage. Due to its design, the device remains in a safe state even in the event of an error (e.g. rusted ratchet pawl, broken springs or other influences such as basic corrosion or dirt).

EXCELLENT CORROSION PROTECTION

A housing optimized for outdoor applications (incl. water drainage holes on all sides) prevents a build up of water and the influence of moisture in extreme conditions (e.g. rain, fluctuations in temperature). External components such as the chain guide and the stripper are zinc plated. Some of the internal moving parts such as the drive pinion, the ratchet pawl, the load chain wheel and the ratchet are MKS coated (zinc flake coating).

Optional

CHAIN STOP & CHAIN CLAW*

Optionally, the devices can be equipped with our proven and tested YKST chain stop or the KKL chain claw.

*The usage is based on each country's specific regulations.



PATENTED **AUTOMATICALLY ACTING SAFETY GEAR**

DESIGNED FOR OPTIMAL EFFICIENCY & SAFETY

In accordance with EN 1808 -
Safety requirements for suspended access equipment, 8.9.2

In cooperation with BGHM Berufsgenossenschaft Holz und Metall and BG ETEM Energie Textil Elektro Medienerzeugnisse

Extract from BG ETEM statement:

"This is to confirm that the integrated safety gear in the ratchet lever hoist Yale **ERGO 360[®] UT** makes organizational measures such as the parallel use of several devices, the additional insertion of slings or the use and repositioning of an additional chain stopper obsolete.

In accordance with the S-T-O-P principle, the additional safety gear represents a technical solution that is superior to the organizational solutions used to date."

drain holes on all sides of the housing prevent standing water and moisture

Yale **ERGO 360**® UT *Utility!*

automatically acting safety gear

push button to fully reset the safety gear

direction indicator

patented hand lever

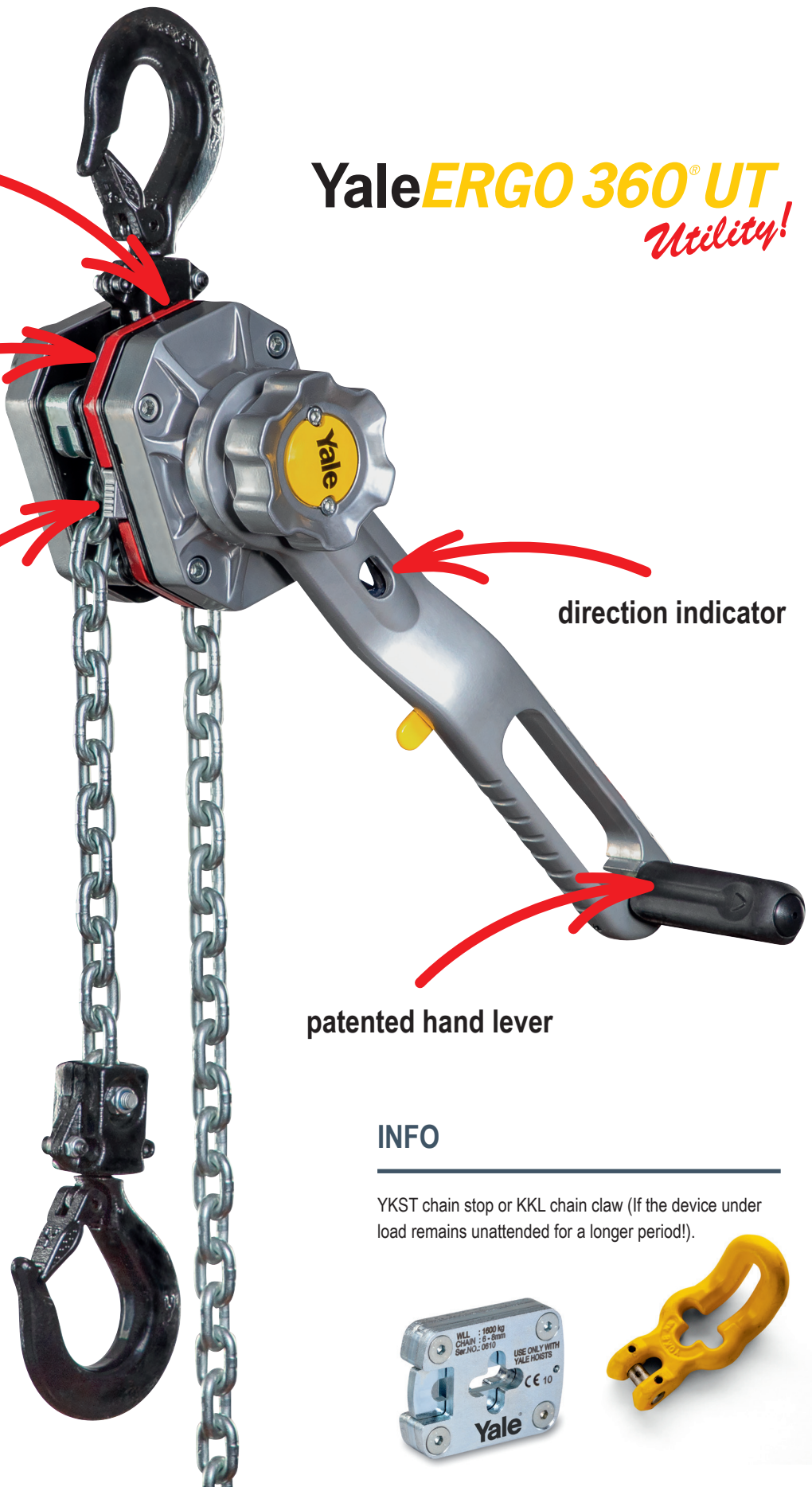

INFO

YKST chain stop or KKL chain claw (If the device under load remains unattended for a longer period!).



STRUCTURE & FUNCTIONALITY OF THE AUTOMATIC SAFETY GEAR

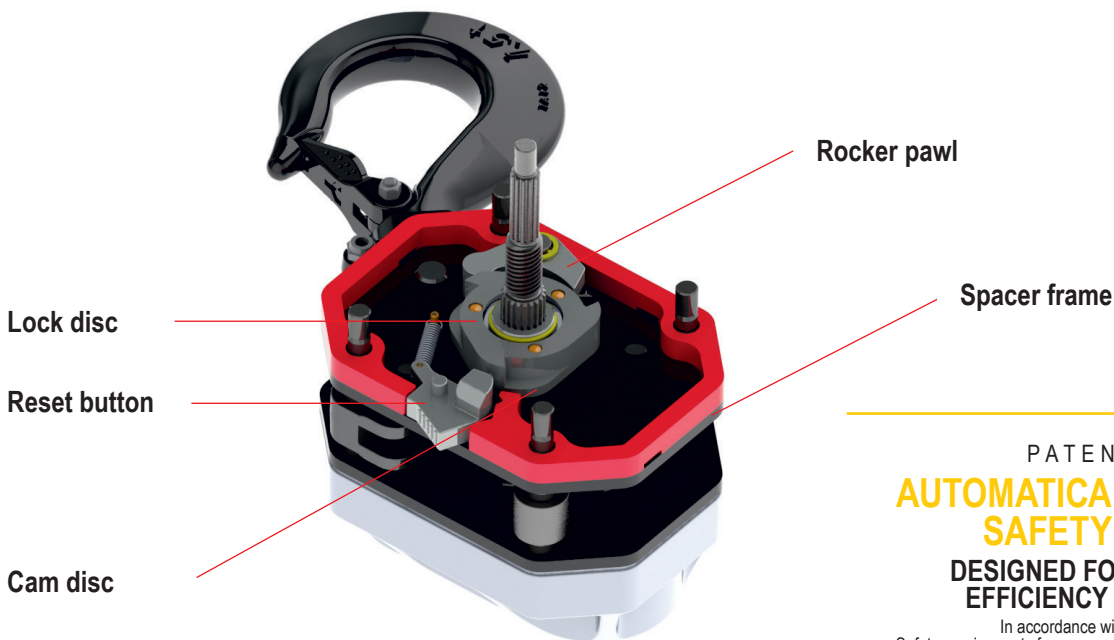

PATENTED
**AUTOMATICALLY ACTING
 SAFETY GEAR**
 DESIGNED FOR OPTIMAL
 EFFICIENCY & SAFETY

In accordance with EN 1808 -
 Safety requirements for suspended access equipment, 8.9.2

REQUIREMENTS FOR THE REDUNDANT SAFETY GEAR in accordance with EN 1808 - Safety requirements for suspended access equipment, 8.9.2

- shall automatically engage in the event of overspeed (more than 0.5 m/s)
- the stopping distance must not exceed 500 mm
- shall be capable of being reset
- shall be capable of being tested
- shall permit lifting at any time

FUNCTION NORMAL OPERATION

Speed < 0.5 m/s

The rocker pawl moves continuously along the contours of the cam disc and lock disc.

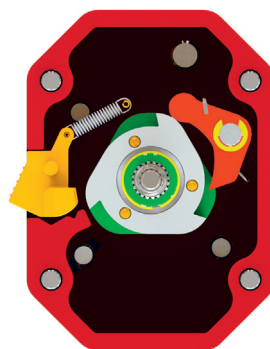

FUNCTION ABSORPTION

Speed > 0.5 m/s

As soon as the speed exceeds 0.5 m/s, the rocker pawl engages the lock disc and safely absorbs the load.

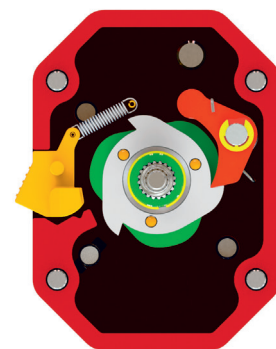

INFO

In any cases the load is caught exceeding a speed of 0.5 m/s.

Speeds below 0.5 m/s (corresponds to 2 km/h) are not safety relevant according to EN 1808.

Extensive corrosion protection measures of the individual components ensure the proper functioning of the safety gear even during long-term use under poor weather conditions.

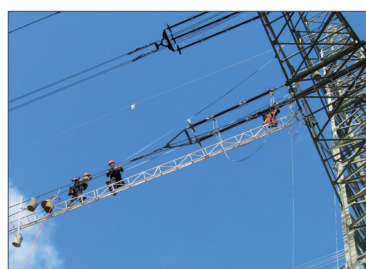

Overhead line construction



Aerial construction

Technical data YaleERGO 360[®] UT

Model	Art.-No.	Capacity kg	Number of chain falls	Chain dimensions d x p in mm/ design	Lift with one full lever turn mm	Handle pull at WLL daN	Handle pull at WLL with crank daN	Weight at standard lift (1.5 m) kg
YaleERGO 360 UT 1500	192069625	1500	1	7.1 x 21 - T	21.7	31	24	9.8
YaleERGO 360 UT 3000	192069671	3000	1	10 x 28 - V	20.1	43	35	18.1
YaleERGO 360 UT 6000	192071416	6000	2	10 x 28 - V	10.1	46	37	29.8
YaleERGO 360 UT 9000	192083321	9000	3	10 x 28 - V	6.7	50	41	50.4

Dimensions YaleERGO 360[®] UT

Model	YaleERGO 360 UT 1500	YaleERGO 360 UT 3000	YaleERGO 360 UT 6000	YaleERGO 360 UT 9000
A min., mm	375	445	563	695
B, mm	26	37	45	68
C, mm	31	40	47	68
D, mm	21	28	35	50
E, mm	327	377	377	377
F, mm	300	350	350	350
G, mm	51	57	71	116
H, mm	96	123	162	199
J, mm	147	180	233	315
K, mm	69	86	86	86
L, mm	124	136	136	136
M, mm	193	222	222	222
N mm	30	30	30	30
O, mm	120	120	120	120
P, mm	287	314	314	314

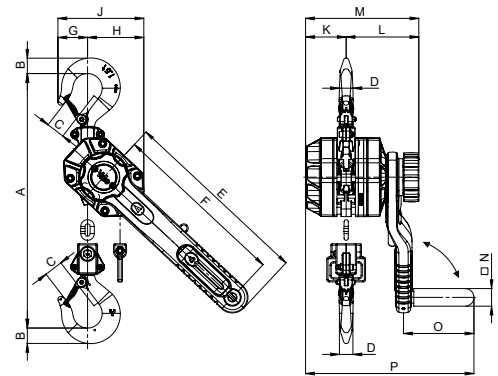

YaleERGO 360[®] UT, 1500 - 3000 kg, single fall

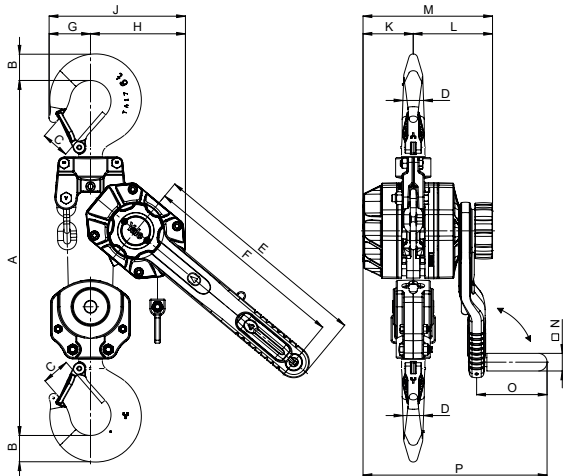

YaleERGO 360[®] UT, 6000 kg, double fall

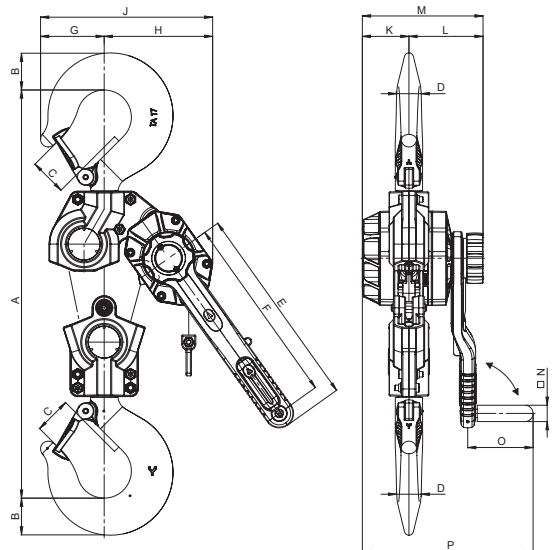

YaleERGO 360[®] UT, 9000 kg, three fall



Construction of contact lines



Cable car construction



Positioning of loads