



C 85 Ratchet lever hoist with roller chain

Capacity 750 - 3000 kg

D 85 Ratchet lever hoist with link chain

Capacity 750 - 10000 kg

Almost unlimited applications in maintenance, mining, construction, steel fabrication, shipbuilding and utility work. Ideal for moving and positioning heavy machines and securing heavy loads, simplifies setting pipes etc. in manholes and trenches.

Features

- Enclosed housing with housing cover, handlever and bottom block made from high tensile white malleable cast iron for overall rugged construction.
- Wet painting colour code RAL 1023.
- The graphite cast iron load sheave for the link chain has precision machined chain pockets for accurate fit and durability of the load chain.
- The roller chain sprocket is made from heat treated chromium-molybdenum steel with precision machined teeth to ensure smooth chain movement.
- Alloyed steel link chain with zinc-plated, in accordance with national and international standards and regulations.

INFO

Since 1936, the Velbert factory has built over 1 million units!

All ratchet lever hoists with a capacity exceeding 750 kg can be used for load attachment according to EN 12195.

Yale hoists and trolleys are not designed for passenger elevation applications and must not be used for this purpose.



We are pleased to send you our new Atex catalogue in PDF format.

Technical data C 85

Model	Art.-No.	Capacity kg	Number of chain falls	Chain dimensions p x b _i	Chain dimensions p x b _i	Lift with one full lever turn mm	Handle pull at WLL daN	Weight at standard lift (1.5 m) kg
				Zoll	mm			
PUL-LIFT C 85 750	N01141295	750	1	5/8" x 3/8"	15.875 x 9.65	115	38	8.7
PUL-LIFT C 85 1500	N01141296	1500	1	1" x 1/2"	25.4 x 12.7	45	31	17.0
PUL-LIFT C 85 3000	N01141297	3000	1	1 1/4" x 5/8"	31.75 x 15.875	36	40	22.2

Dimensions C 85

Model	PUL-LIFT C 85 750	PUL-LIFT C 85 1500	PUL-LIFT C 85 3000
A min., mm	322	389	403
B, mm	21	27	35
C, mm	27	30	34
D, mm	15	20	25
D1, mm	17	23	25
E, mm	443	443	570
F, mm	112	189	197
G, mm	56	134	142
H, mm	56	55	55
J, mm	142	171	179
K, mm	39	72	76
L, mm	103	99	103

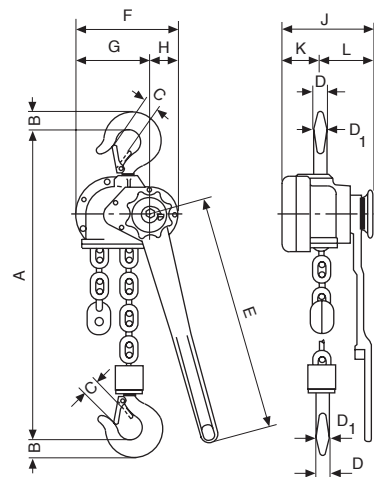

Technical data D 85

Model	Art.-No.	Capacity kg	Number of chain falls	Chain dimensions d x p in mm/ Version	Lift with one full lever turn mm	Handle pull at WLL daN	Weight at standard lift (1.5 m) kg
PUL-LIFT D 85 750	N01541291	750	1	6 x 18.5 - T	111	38	8.2
PUL-LIFT D 85 1500	N01541292	1500	1	9 x 27 - T	45	31	16.3
PUL-LIFT D 85 3000	N01541293	3000	1	11 x 31 - T	33	40	19.6
PUL-LIFT D 85 6000	N01541294	6000	2	11 x 31 - T	17	42	32.9
PUL-LIFT D 85 10000	N01541511	10000	3	11 x 31 - T	11	37	60.0

Dimensions D 85

Model	PUL-LIFT D 85 750	PUL-LIFT D 85 1500	PUL-LIFT D 85 3000	PUL-LIFT D 85 6000	PUL-LIFT D 85 10000
A min., mm	322	389	403	532	805
B, mm	21	27	35	48	61
C, mm	27	30	34	46	54
D, mm	15	20	25	40	40
D1, mm	17	23	25	40	45
E, mm	443	443	570	570	570
F, mm	112	189	197	197	305
G, mm	56	134	142	142	163
H, mm	56	55	55	55	142
J, mm	142	171	179	218	218
K, mm	39	72	76	76	76
L, mm	103	99	103	142	142