

# HA Lifting Point (UNC)

## HA Lifting Point (UNC)

The HA lifting point (UNC) is a bolt-on load attachment product designed for use with loads that incorporate tapped holes. It can rotate 360° around the bolt axis, as well as pivot 90°, allowing the lifting point to orientate to the appropriate angle of lift, mitigating the risk of damage. The HA lifting point (UNC) is suitable for both top and side mounting, and maintains its full working load limit even when pulled at 90°.

**Standards:** designed and manufactured in accordance with EN1677-1 and ASME B30.26.

**Product sizes:** available in sizes 3/8" to 2" and with working load limits from 0.63 tonnes to 20.0 tonnes.

**Product markings:** forged bail marked with manufacturer name "Hackett" and batch number for product material traceability. Body marked with working load limit in tonnes (based on 4 : 1 safety factor) and batch number. Bolt marked with UNC size, material grade, working load limit in tonnes (based on 4 : 1 safety factor), and batch number for bolt material traceability.

**Temperature:** operational temperature range of -40°C to +200°C without reduction in working load limit.

**Material:** alloy steel.

**Bolt Grade:** 10.9.

**Testing:** load rated parts are subject to 100% magnaflux crack detection following heat treatment. HA lifting points are proof tested to 2.5 times working load limit, and fatigue rated to 1.5 times working load limit.

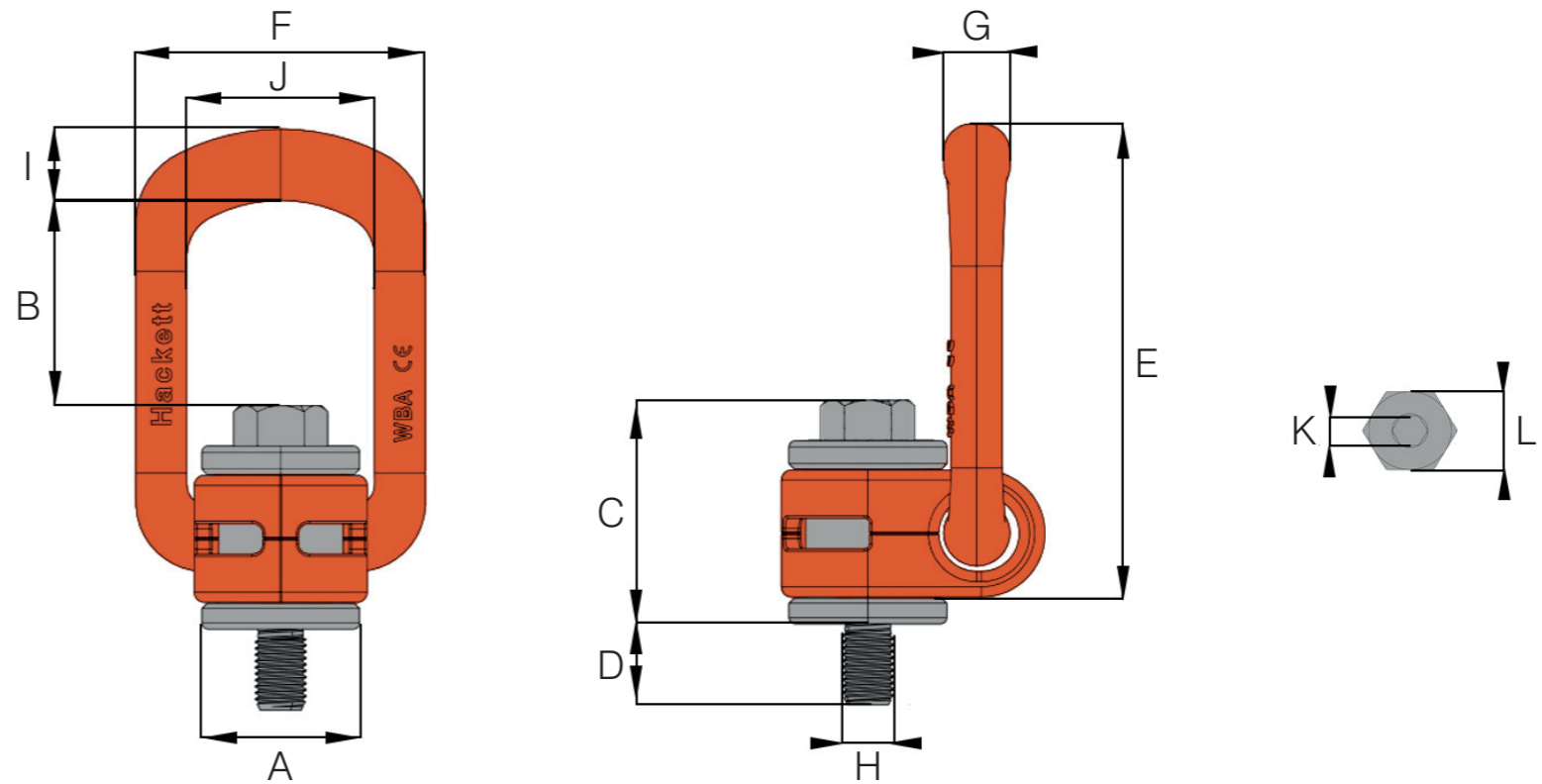

## Specifications

PART CODE	WLL t	THREAD inch	A inch	B inch	C inch	D inch	E inch	F inch	G inch	H inch	I inch	J inch	K inch	L inch	TORQUE Nm	MASS lbs
8-H17-UNC10G	0.63	3/8-16UNC-2A	1.22	1.65	1.69	0.63	3.88	2.24	0.51	0.38	0.55	1.46	0.24	0.63	25	1.10
8-H17-UNC12G	1.0	1/2-13UNC-2A	1.22	1.57	1.77	0.83	3.88	2.24	0.51	0.50	0.55	1.46	0.31	0.71	30	1.10
8-H17-UNC16G	1.5	5/8-11UNC-2A	1.22	1.46	1.89	0.94	3.88	2.24	0.51	0.63	0.55	1.46	0.39	0.94	35	1.10
8-H17-UNC20G	2.5	3/4-10UNC-2A	1.77	2.68	2.28	1.02	5.63	3.23	0.63	0.75	0.65	2.13	0.47	1.18	80	3.31
8-H17-UNC22G	2.5	7/8-9UNC-2A	1.77	2.56	2.40	1.02	5.63	3.23	0.63	0.88	0.65	2.13	0.55	1.42	150	3.31
8-H17-UNC26G	4.0	1-8UNC-2A	1.77	2.56	2.40	1.42	5.63	3.23	0.63	1.00	0.65	2.13	0.55	1.42	260	3.31
8-H17-UNC32G	5.0	1-1/4-7UNC-2A	2.32	2.83	3.15	1.89	6.69	3.90	0.87	1.25	0.87	2.56	0.67	1.81	450	7.72
8-H17-UNC36G	8.0	1-1/2-6UNC-2A	2.72	3.74	4.09	2.44	8.92	4.84	1.08	1.50	1.06	3.35	0.87	2.17	550	13.23
8-H17-UNC42G	15.0	1-3/4-5UNC-2A	3.86	4.19	4.57	2.48	10.14	6.22	1.42	1.75	1.42	4.09	0.87	2.56	650	24.25
8-H17-UNC48G	20.0	2-4.5UNC-2A	3.86	4.49	4.25	2.83	10.14	6.22	1.42	2.00	1.42	4.09	1.06	2.95	700	26.46

mharwood@rhtltd.co.uk

www.rhtltd.co.uk

+44 (0)1953 889998



# HA Lifting Point (UNC)

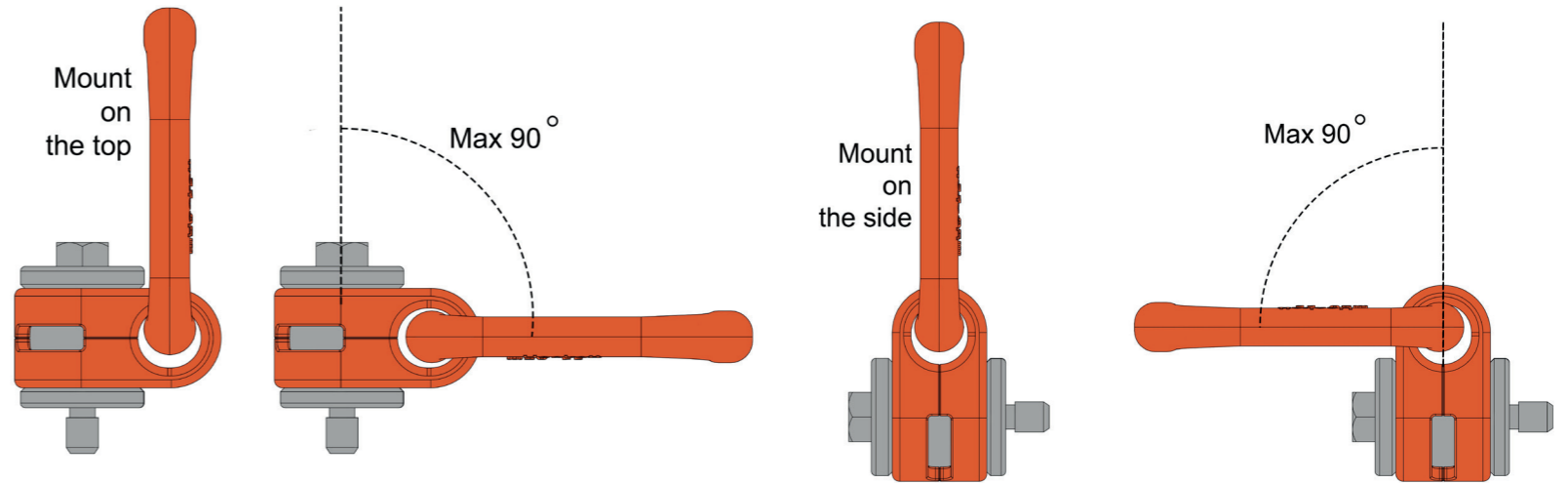

<b>NUMBER OF LEGS</b>	1	2	1	2	2	2	2	3-4	3-4	3-4	
Load Direction	0°	0°	90°	90°	0-45°	45-60°	unsym	0-45°	45-60°	unsym	
<b>PART CODE</b>	<b>THREAD</b>	<b>WLL (in tonnes) BY LIFTING APPLICATION</b>									
8-H17-UNC10G	3/8-16UNC-2A	0.63	1.26	0.63	1.26	0.88	0.63	0.63	1.32	0.94	0.63
8-H17-UNC12G	1/2-13UNC-2A	1.0	2.0	1.0	2.0	1.4	1.0	1.0	2.1	1.5	1.0
8-H17-UNC16G	5/8-11UNC-2A	1.5	3.0	1.5	3.0	2.1	1.5	1.5	3.15	2.25	1.5
8-H17-UNC20G	3/4-10UNC-2A	2.5	5.0	2.5	5.0	3.5	2.5	2.5	5.25	3.75	2.5
8-H17-UNC22G	7/8-9UNC-2A	2.5	5.0	2.5	5.0	3.5	2.5	2.5	5.25	3.75	2.5
8-H17-UNC26G	1-8UNC-2A	4.0	8.0	4.0	8.0	5.6	4.0	4.0	8.4	6.0	4.0
8-H17-UNC32G	1-1/4-7UNC-2A	5.0	10.0	5.0	10.0	7.0	5.0	5.0	10.5	7.5	5.0
8-H17-UNC36G	1-1/2-6UNC-2A	8.0	16.0	8.0	16.0	11.2	8.0	8.0	16.8	12.0	8.0
8-H17-UNC42G	1-3/4-5UNC-2A	15.0	30.0	15.0	30.0	21.0	15.0	15.0	31.5	22.5	15.0
8-H17-UNC48G	2-4.5UNC-2A	20.0	40.0	20.0	40.0	28.0	20.0	20.0	42.0	30.0	20.0