

HA Lifting Point (Metric)

HA Lifting Point (Metric)

The HA lifting point (metric) is a load attachment product designed for use with loads that incorporate tapped holes. It can rotate 360° around the bolt axis, as well as pivot 90°, allowing the lifting point to orientate to the appropriate angle of lift, mitigating the risk of damage. The HA lifting point (metric) is suitable for both top and side mounting, and maintains its full working load limit even when pulled at 90°.

Standards: designed and manufactured in accordance with EN1677-1 and ASME B30.26.

Product sizes: available in sizes M8 to M48 and with working load limits from 0.3 tonnes to 20.0 tonnes.

Product markings: forged bail marked with manufacturer name "Hackett" and batch number for product material traceability. Body marked with working load limit (based on 4 : 1 safety factor) and batch number. Bolt marked with metric size, material grade, working load limit (based on 4 : 1 safety factor), and batch number for bolt material traceability.

Temperature: operational temperature range of -40°C to +200°C without reduction in working load limit.

Material: alloy steel.

Bolt Grade: 10.9.

Testing: load rated parts are subject to 100% magnaflux crack detection following heat treatment. HA lifting points are proof tested to 2.5 times working load limit, and fatigue rated to 20,000 cycles at 1.5 times working load limit.

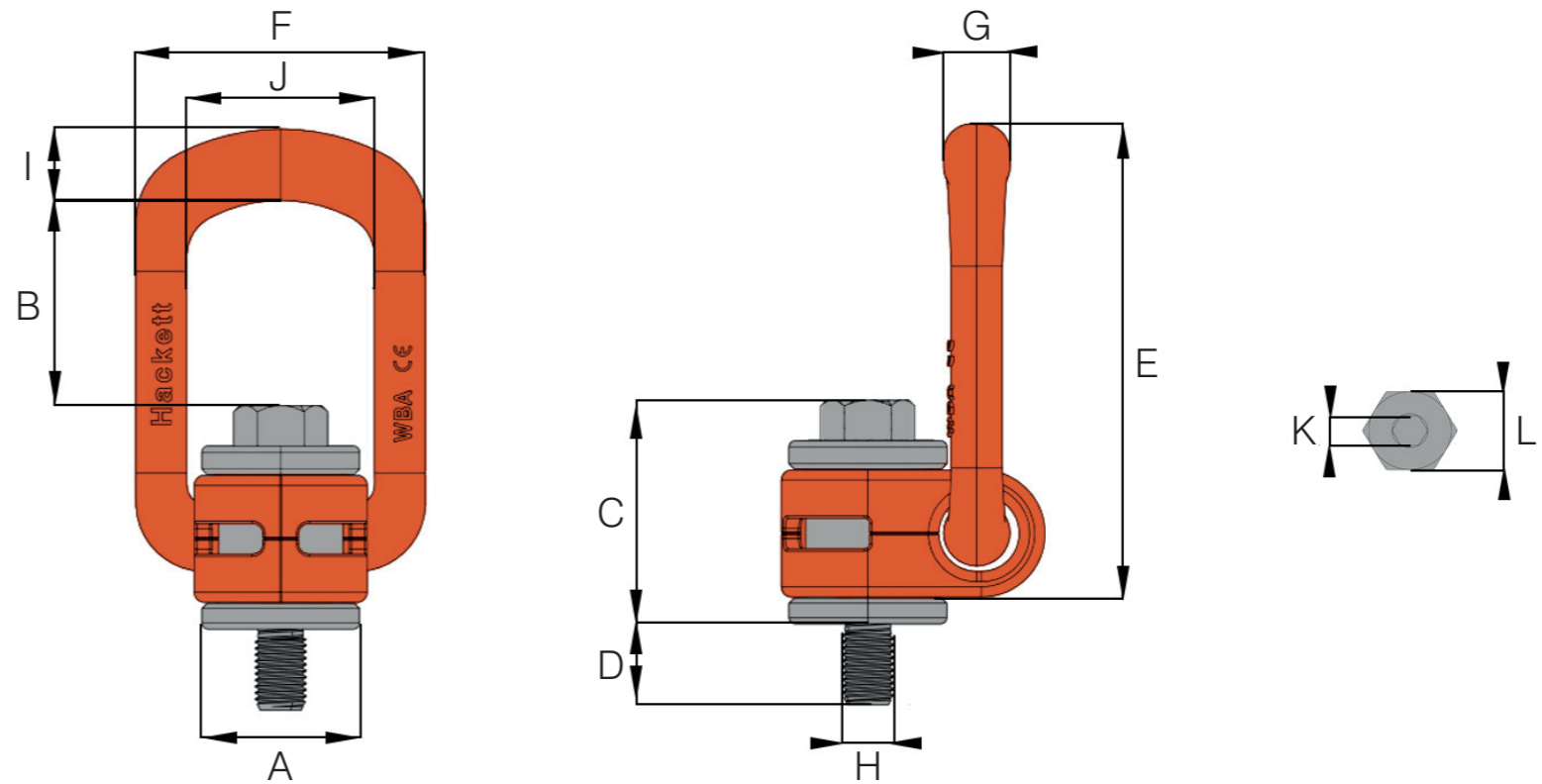

Specifications

PART CODE	WLL t	THREAD M	A mm	B mm	C mm	D mm	E mm	F mm	G mm	H mm	I mm	J mm	K mm	L mm	TORQUE Nm	MASS kg
8-H17-M08G	0.3	M8 x 1.25-6g	31	43	42	11	98.5	57	13	8	14	37	6	13	25	0.5
8-H17-M10G	0.63	M10 x 1.5-6g	31	41	44	16	98.5	57	13	10	14	37	6	16	30	0.5
8-H17-M12G	1.0	M12 x 1.75-6g	31	40	45	18	98.5	57	13	12	14	37	8	18	35	0.5
8-H17-M16G	1.5	M16 x 2.0-6g	31	37	48	24	98.5	57	13	16	14	37	10	24	80	0.5
8-H17-M20G	2.5	M20 x 2.5-6g	45	68	58	30	143	82	16	20	16	54	12	30	150	1.5
8-H17-M24G	4.0	M24 x 3.0-6g	45	65	61	36	143	82	16	24	16.5	54	14	36	260	1.5
8-H17-M30G	5.0	M30 x 3.5-6g	59	66	82	48	170	99	22	30	22	65	17	46	400	3.5
8-H17-M36G	8.0	M36 x 4-6g (8t)	69	95	104	62	226.5	123	27.5	36	27	85	22	55	550	6.0
8-H17-M42G	15.0	M42 x 4.5-6g (15t)	98	104.5	117	63	257.5	158	36	42	36	104	22	65	650	11.0
8-H17-M48G	20.0	M48 x 5-6g	98	101.5	120	72	257.5	158	36	48	36	104	27	75	700	12.0

mharwood@rhtltd.co.uk

www.rhtltd.co.uk

+44 (0)1953 889998



HA Lifting Point (Metric)

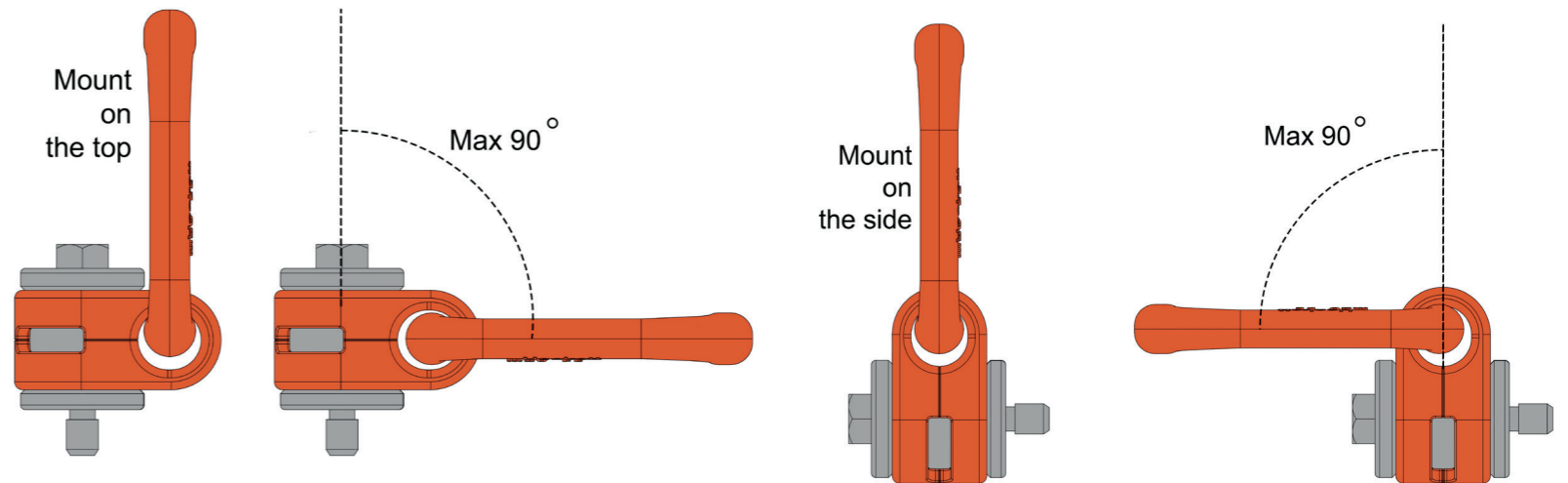

NUMBER OF LEGS	1	2	1	2	2	2	2	3-4	3-4	3-4	
Load Direction	0°	0°	90°	90°	0-45°	45-60°	unsym	0-45°	45-60°	unsym	
PART CODE	THREAD	WLL (in tonnes) BY LIFTING APPLICATION									
8-H17-M08G	M8 x 1.25-6g	0.3	0.6	0.3	0.6	0.42	0.3	0.3	0.63	0.45	0.3
8-H17-M10G	M10 x 1.5-6g	0.63	1.26	0.63	1.26	0.88	0.63	0.63	1.32	0.94	0.63
8-H17-M12G	M12 x 1.75-6g	1.0	2.0	1.0	2.0	1.4	1.0	1.0	2.1	1.5	1.0
8-H17-M16G	M16 x 2.0-6g	1.5	3.0	1.5	3.0	2.1	1.5	1.5	3.15	2.25	1.5
8-H17-M20G	M20 x 2.5-6g	2.5	5.0	2.5	5.0	3.5	2.5	2.5	5.25	3.75	2.5
8-H17-M24G	M24 x 3.0-6g	4.0	8.0	4.0	8.0	5.6	4.0	4.0	8.4	6.0	4.0
8-H17-M30G	M30 x 3.5-6g	5.0	10.0	5.0	10.0	7.0	5.0	5.0	10.5	7.5	5.0
8-H17-M36G	M36 x 4-6g (8t)	8.0	16.0	8.0	16.0	11.2	8.0	8.0	16.8	12.0	8.0
8-H17-M42G	M42 x 4.5-6g (15t)	15.0	30.0	15.0	30.0	21.0	15.0	15.0	31.5	22.5	15.0
8-H17-M48G	M48 x 5-6g	20.0	40.0	20.0	40.0	28.0	20.0	20.0	42.0	30.0	20.0