

HA Weld-on Excavator Hook

The HA weld-on excavator hook is a load attachment product that is used as a fixed anchor in lifting and towing applications. As its name suggests, it is specifically designed to be permanently attached by welding to a structure or surface. It features a large, generous aperture for easy connection with a wide range of lifting and towing equipment, such as chain sling components and polyester straps. The excavator hooks are fitted with heavy duty steel latches. The latch and excavator hook tips are integrated creating a strong and robust hook closure. Manufactured from alloy steel, the HA weld-on excavator hook delivers an excellent balance between toughness and ductility.

Standards: designed and manufactured in accordance with EN1677-1.

Product sizes: available with working load limits from 1 tonne to 10 tonnes.

Temperature: operational temperature range of - 40°C to + 200°C without reduction in working load limit.

Material: made of alloy steel.

Testing: load rated parts are subject to 100% magnaflux crack detection following heat treatment. HA weld-on lifting points are proof tested to 2.5 times working load limit, and fatigue rated to 1.5 times working load limit.

Safety factor: 4 : 1.

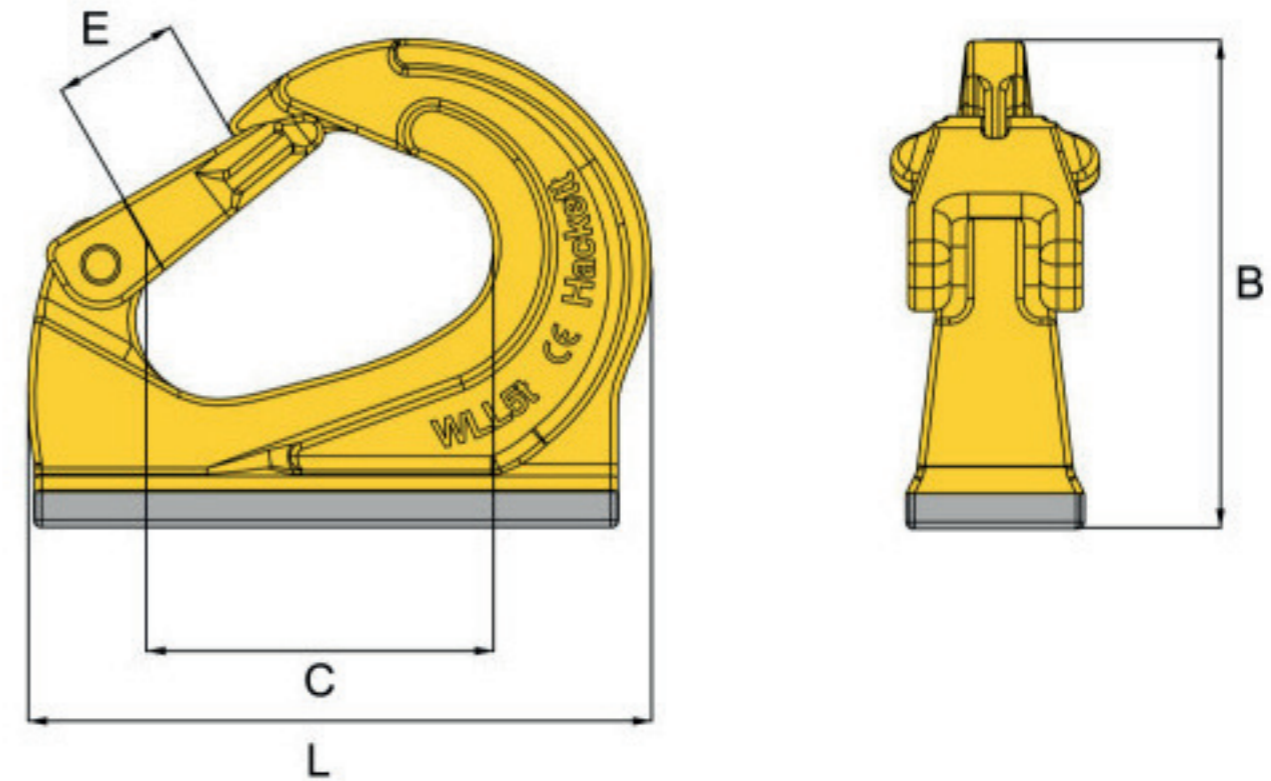

Specifications

PART CODE	WLL tonnes	B mm	C mm	E mm	L mm	BOX QTY.	MASS Kg
8-H26-01	1.00	77.6	61.3	25	101.6	30	0.49
8-H26-02	2.00	92.0	67.0	28	114.0	20	0.87
8-H26-03	3.00	106.0	73.5	30	129.0	15	1.13
8-H26-05	5.00	133.0	94.0	39	171.0	8	2.50
8-H26-08	8.00	137.0	94.0	36	177.0	6	3.26
8-H26-10	10.00	170.0	135.0	48	223.0	4	5.20

HA Weld-on Excavator Hook

The HA weld-on excavator hook is a load attachment product that is used as a fixed anchor in lifting and towing applications. As its name suggests, it is specifically designed to be permanently attached by welding to a structure or surface. It features a large, generous aperture for easy connection with a wide range of lifting and towing equipment, such as chain sling components and polyester straps. The excavator hooks are fitted with heavy duty steel latches. The latch and excavator hook tips are integrated creating a strong and robust hook closure. Manufactured from alloy steel, the HA weld-on excavator hook delivers an excellent balance between toughness and ductility.

Standards: designed and manufactured in accordance with EN1677-1.

Product sizes: available with working load limits from 2200 lbs to 22000 lbs.

Temperature: operational temperature range of - 40°C to + 200°C without reduction in working load limit.

Material: made of alloy steel.

Testing: load rated parts are subject to 100% magnaflux crack detection following heat treatment. HA weld-on lifting points are proof tested to 2.5 times working load limit, and fatigue rated to 1.5 times working load limit.

Safety factor: 4 : 1.

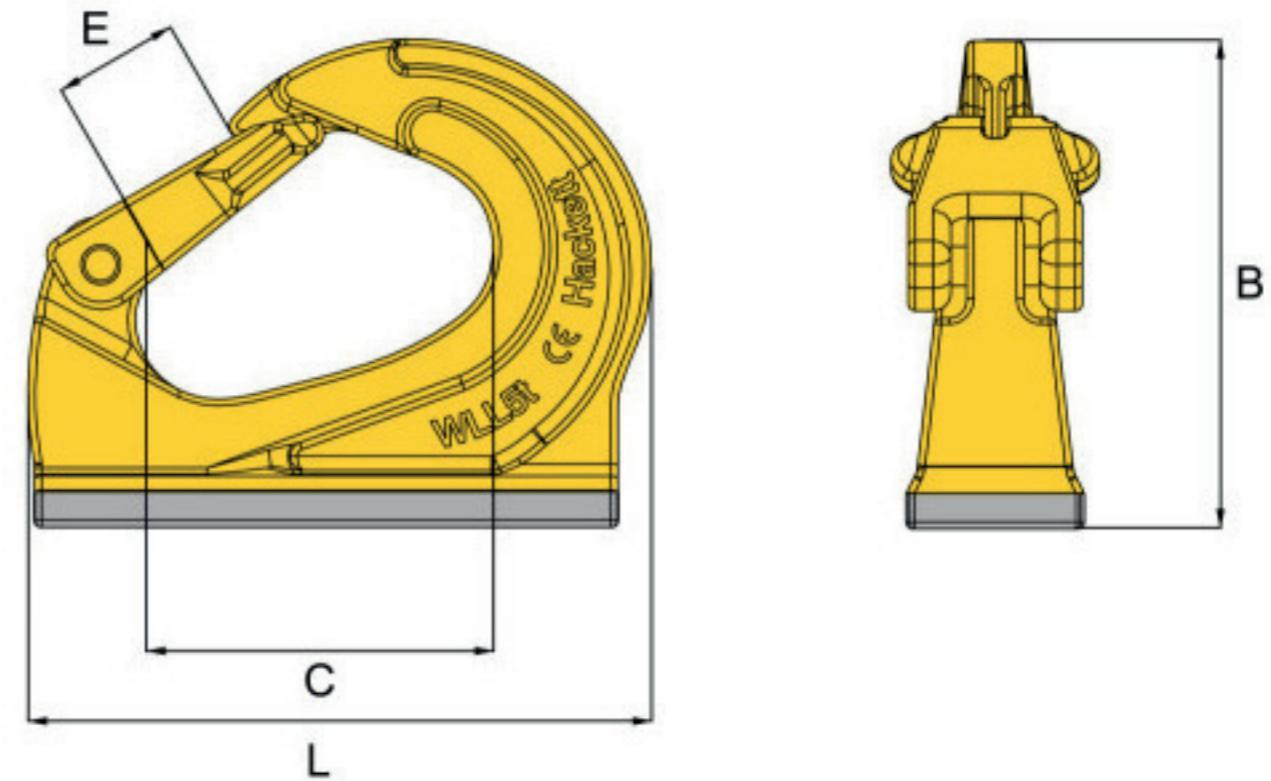

Specifications

PART CODE	WLL lbs	B inch	C inch	E inch	L inch	BOX QTY.	MASS lbs
8-H26-01	2200	3.06	2.41	0.98	4.00	30	1.08
8-H26-02	4400	3.62	2.64	1.10	4.49	20	1.92
8-H26-03	6600	4.17	2.89	1.18	5.08	15	2.49
8-H26-05	11000	5.24	3.70	1.54	6.73	8	5.51
8-H26-08	17600	5.39	3.70	1.42	6.97	6	7.19
8-H26-10	22000	6.69	5.31	1.89	8.78	4	11.46