



# Hack10 Clevis Foundry Hook

## Hack10 Clevis Foundry Hook

The Hack10 clevis foundry hook is typically used for lifting and handling molds and casting pots in foundries, although it is also suitable for lifting applications where human interaction with the hook and the load is not possible due to human safety. This hook features a long nib that allows for easy insertion into eye fittings. It also has a generous hook aperture and bowl which is designed to accommodate trunnions on the load. Manufactured from alloy steel, the Hack10 foundry hook is 25% stronger than a grade 8 equivalent, delivering a greater working load limit without the need for a larger diameter chain sling.

**Standards:** designed and manufactured in accordance with EN1677-1, ASTM A952/A952M, and DIN PAS 1061 and suitable for use in chain slings certified to EN818-4.

**Product sizes:** available for chain sizes from 8mm to 16mm and with working load limits from 2.5 tonnes to 10.0 tonnes.

**Temperature:** operational temperature range of - 40°C to + 200°C without reduction in working load limit.

**Material:** alloy steel.

**Testing:** crack detection following heat treatment, and proof load tested to 2.5 times working load limit.

**Safety factor:** 4 : 1.

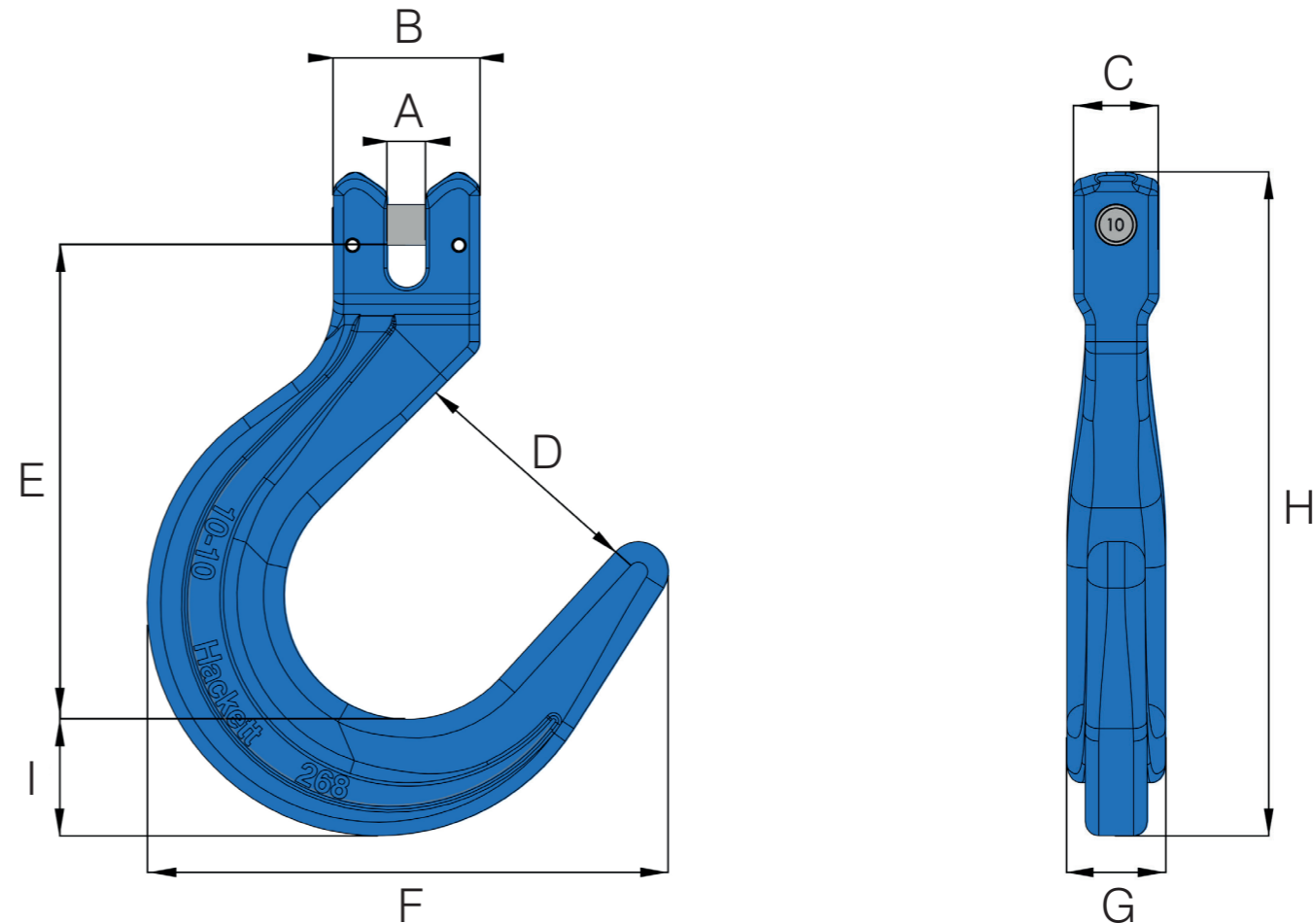

## Metric Specifications

PART CODE	CHAIN SIZE mm	A mm	B mm	C mm	D mm	E mm	F mm	G mm	H mm	I mm	BOX QTY.	WLL tonnes	MASS kg
10-H20-08	8	9.5	36.0	23.0	62.0	114.0	128.0	20.0	160.0	27.0	20	2.5	0.80
10-H20-10	10	12.5	48.0	29.5	72.0	138.0	153.0	25.0	192.0	31.0	10	4.0	1.42
10-H20-13	13	15.0	59.0	35.0	88.0	165.0	186.0	33.0	232.0	39.0	6	6.7	2.88
10-H20-16	16	18.5	70.0	46.0	103.0	198.0	218.0	40.0	284.0	50.0	4	10.0	5.10

enquiries@rhtltd.co.uk

www.rhtltd.co.uk

+44 (0) 1953 889998





# Hack10 Clevis Foundry Hook

## Hack10 Clevis Foundry Hook

The Hack10 clevis foundry hook is typically used for lifting and handling molds and casting pots in foundries, although it is also suitable for lifting applications where human interaction with the hook and the load is not possible due to human safety. This hook features a long nib that allows for easy insertion into eye fittings. It also has a generous hook aperture and bowl which is designed to accommodate trunnions on the load. Manufactured from alloy steel, the Hack10 foundry hook is 25% stronger than a grade 8 equivalent, delivering a greater working load limit without the need for a larger diameter chain sling.

**Standards:** designed and manufactured in accordance with EN1677-1, ASTM A952/A952M, and DIN PAS 1061 and suitable for use in chain slings certified to EN818-4.

**Product sizes:** available for chain sizes from 5/16 inch to 5/8 inch and with working load limits from 5,700 lbs to 22,600 lbs.

**Temperature:** operational temperature range of - 40°C to + 200°C without reduction in working load limit.

**Material:** alloy steel.

**Testing:** crack detection following heat treatment, and proof load tested to 2.5 times working load limit.

**Safety factor:** 4 : 1.

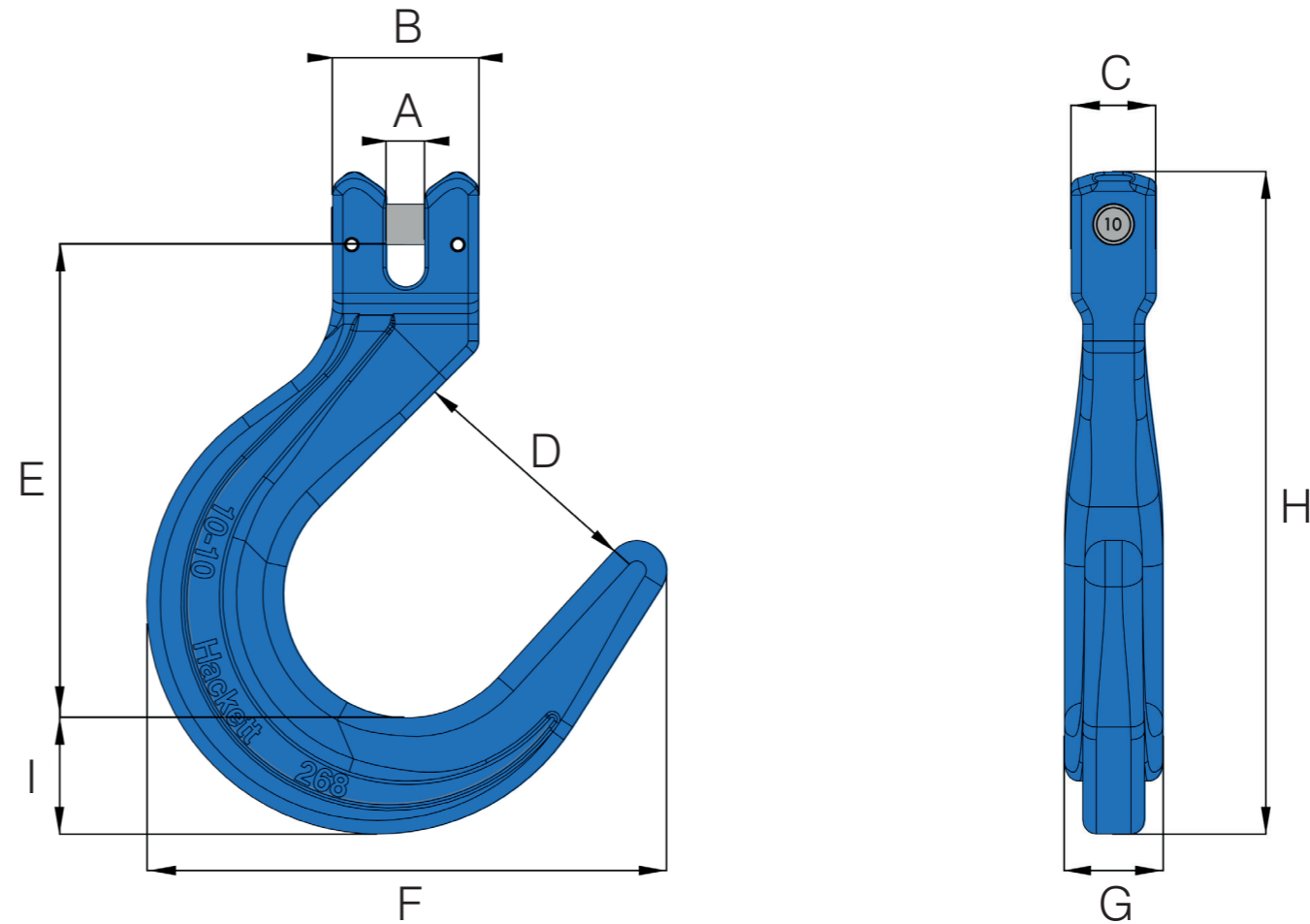

### Imperial Specifications

PART CODE	CHAIN SIZE inch	A inch	B inch	C inch	D inch	E inch	F inch	G inch	H inch	I inch	BOX QTY.	WLL lbs	MASS lbs
10-H20-08	5/16	0.37	1.42	0.91	2.44	4.49	5.04	0.79	6.30	1.06	20	5700	1.76
10-H20-10	3/8	0.49	1.89	1.16	2.83	5.43	6.02	0.98	7.56	1.22	10	8800	3.13
10-H20-13	1/2	0.59	2.32	1.38	3.46	6.50	7.32	1.30	9.13	1.54	6	15000	6.35
10-H20-16	5/8	0.73	2.76	1.81	4.06	7.80	8.58	1.57	11.18	1.97	4	22600	11.24

enquiries@rhtltd.co.uk

www.rhtltd.co.uk

+44 (0) 1953 889998

