

Hack8 Swivel Self Locking Hook

The Hack8 swivel self locking hook incorporates a special latch mechanism that locks itself automatically when it comes under load. Manual interaction of the latch trigger then allows disengagement of the locking mechanism once the load is relieved. It is also fitted with a ball bearing swivel attachment type which allows rotational movement of the hook, even when under load. As a result, this hook is commonly incorporated into single leg slings for use with crane pendant wires. Manufactured from alloy steel, the Hack8 swivel self locking hook delivers an excellent balance between toughness and ductility.

Standards: designed and manufactured in accordance with EN1677-1 and suitable for use in chain slings certified to EN818-4.

Product sizes: available for chain sizes from 7/8mm to 26mm and with working load limits from 2.0 tonnes to 21.20 tonnes.

Temperature: operational temperature range of - 40°C to + 200°C without reduction in working load limit.

Material: alloy steel.

Testing: crack detection following heat treatment, and proof load tested to 2.5 times working load limit.

Safety factor: 4 : 1.

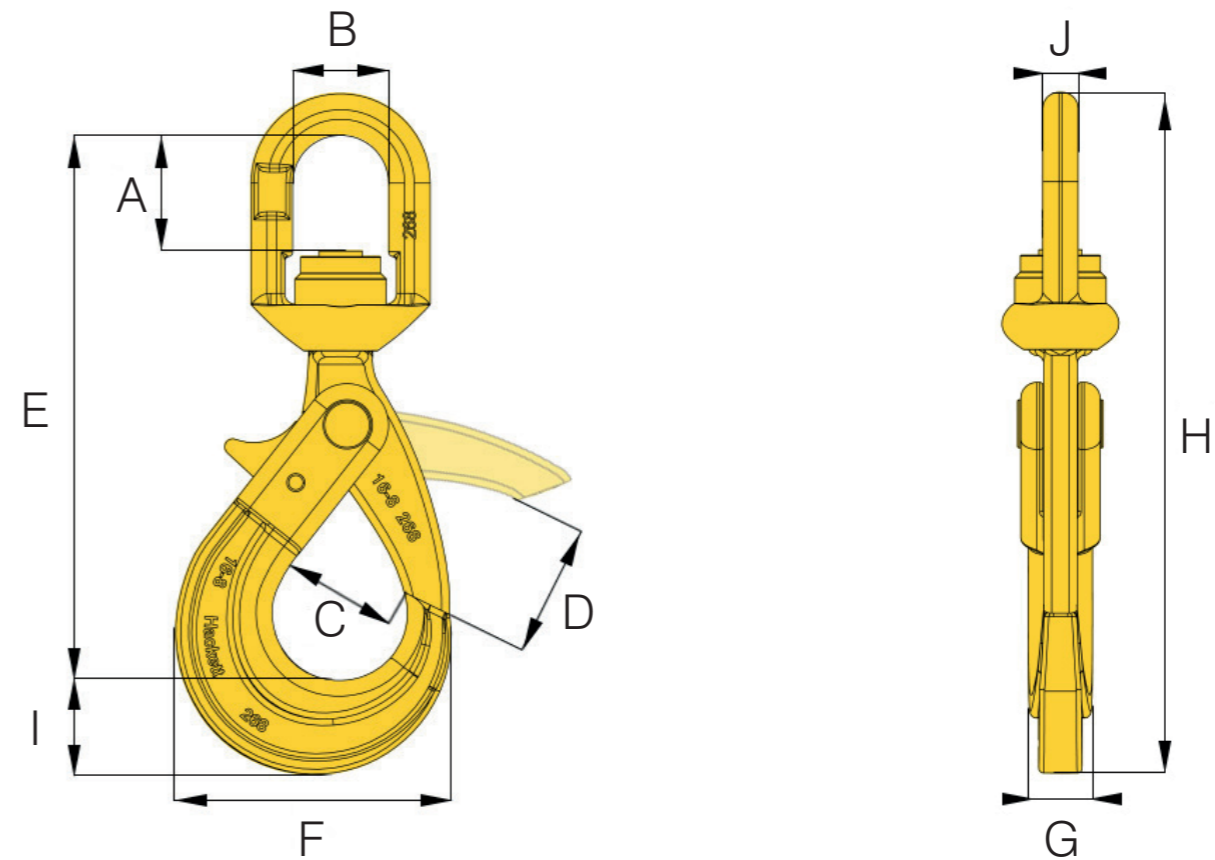

Specifications

Part Code	Chain Size mm	A mm	B mm	C mm	D mm	E mm	F mm	G mm	H mm	I mm	J mm	Box Qty.	WLL tonnes	Mass kg
8-H14-08	7/8	40.0	36.0	35.0	40.0	202.0	91.0	20.0	240.0	26.0	13.0	15	2.00	1.10
8-H14-10	10	49.0	42.0	45.0	48.0	237.0	108.0	26.0	283.0	31.0	15.5	8	3.15	2.00
8-H14-13	13	58.0	50.0	52.5	57.0	282.0	142.0	33.0	343.0	40.0	17.0	6	5.30	4.00
8-H14-16	16	60.0	61.0	63.0	65.0	341.5	168.6	38.0	419.0	50.0	21.5	3	8.00	7.30
8-H14-20	20	73.0	76.0	82.0	82.0	399.5	185.0	50.0	483.0	58.0	26.5	2	12.50	11.60
8-H14-22	22	97.0	97.0	76.0	80.0	466.0	202.0	52.0	564.0	67.0	33.0	1	15.00	16.00
8-H14-26	26	115.0	123.0	96.0	109.0	544.0	239.0	60.0	661.0	75.0	42.0	1	21.20	21.50

Hack8 Swivel Self Locking Hook

The Hack8 swivel self locking hook incorporates a special latch mechanism that locks itself automatically when it comes under load. Manual interaction of the latch trigger then allows disengagement of the locking mechanism once the load is relieved. It is also fitted with a ball bearing swivel attachment type which allows rotational movement of the hook, even when under load. As a result, this hook is commonly incorporated into single leg slings for use with crane pendant wires. Manufactured from alloy steel, the Hack8 swivel self locking hook delivers an excellent balance between toughness and ductility.

Standards: designed and manufactured in accordance with EN1677-1 and suitable for use in chain slings certified to EN818-4.

Product sizes: available for chain sizes from 1/4 - 5/16 inch to 1 inch and with working load limits from 4,500 lbs to 47,700 lbs.

Temperature: operational temperature range of -40°F to +392°F (-40°C to + 200°C) without reduction in working load limit.

Material: alloy steel.

Testing: crack detection following heat treatment, and proof load tested to 2.5 times working load limit.

Safety factor: 4 : 1.

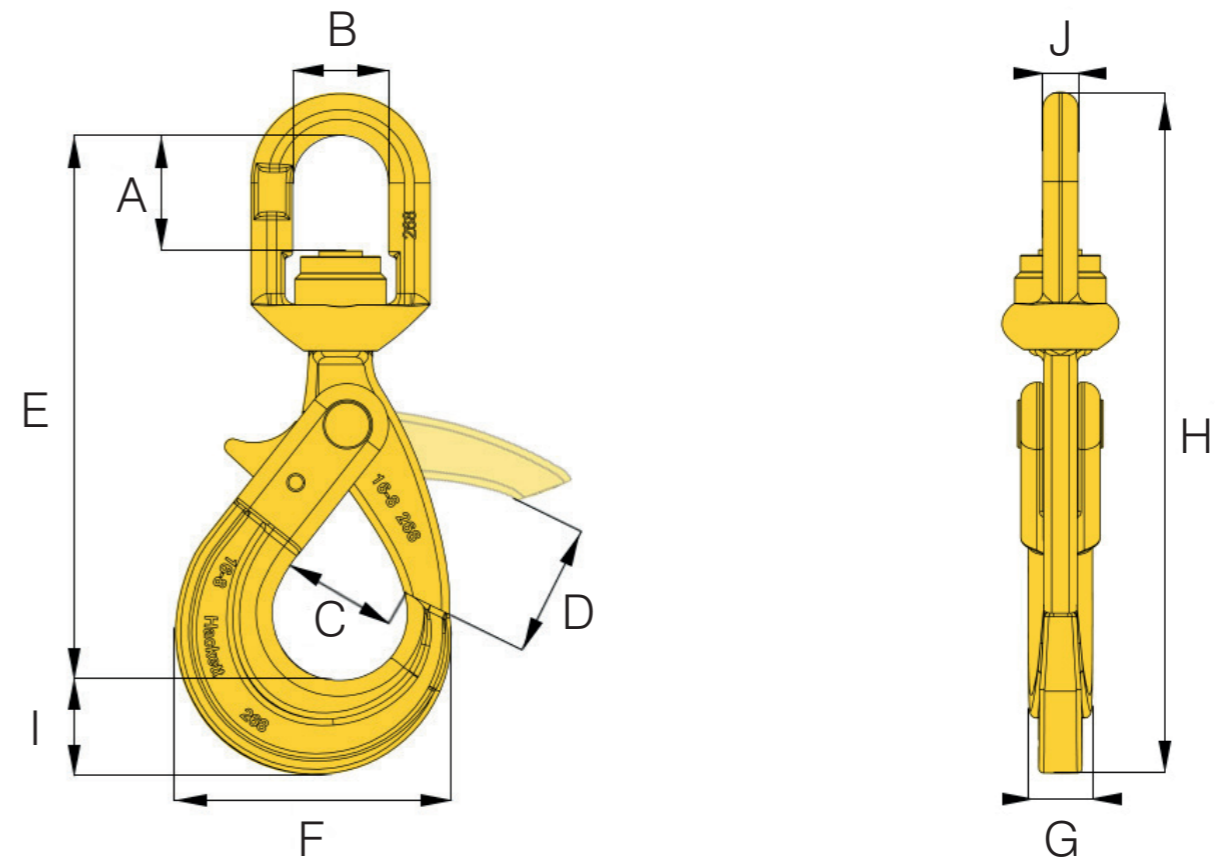

Specifications

Part Code	Chain Size inch	A inch	B inch	C inch	D inch	E inch	F inch	G inch	H inch	I inch	J inch	Box Qty.	WLL lbs	Mass lbs
8-H14-08	1/4 - 5/16	1.57	1.42	1.38	1.57	7.95	3.58	0.79	9.45	1.02	0.51	15	4500	2.43
8-H14-10	3/8	1.93	1.65	1.77	1.89	9.33	4.25	1.02	11.14	1.22	0.61	8	7100	4.41
8-H14-13	1/2	2.28	1.97	2.07	2.24	11.10	5.59	1.30	13.50	1.57	0.67	6	12000	8.82
8-H14-16	5/8	2.36	2.40	2.48	2.56	13.44	6.64	1.50	16.50	1.97	0.85	3	18100	16.09
8-H14-20	3/4	2.87	2.99	3.23	3.23	15.73	7.28	1.97	19.02	2.28	1.04	2	28300	25.57
8-H14-22	7/8	3.82	3.82	2.99	3.15	18.35	7.95	2.05	22.20	2.64	1.30	1	34200	35.27
8-H14-26	1	4.53	4.84	3.78	4.29	21.42	9.41	2.36	26.02	2.95	1.65	1	47700	47.40