

## Hack8 Reeveable Egg Link

The Hack8 reeveable egg link is specifically designed for use in Hackett grade 8 collar slings. The wide link aperture allows another reeveable egg link to pass through, creating a chokage lift. This link is capable of attachment directly onto chain thanks to its clevis attachment type. Manufactured from alloy steel, the Hack8 reeveable egg link delivers an excellent balance between toughness and ductility.

**Standards:** designed and manufactured in accordance with EN1677-1 and suitable for use in chain slings certified to EN818-4.

**Product sizes:** available for chain sizes from 7/8mm to 16mm and with working load limits from 2.0 tonnes to 8.0 tonnes.

**Temperature:** operational temperature range of - 40°C to + 200°C without reduction in working load limit.

**Material:** alloy steel.

**Testing:** crack detection following heat treatment, and proof load tested to 2.5 times working load limit.

**Safety factor:** 4 : 1.

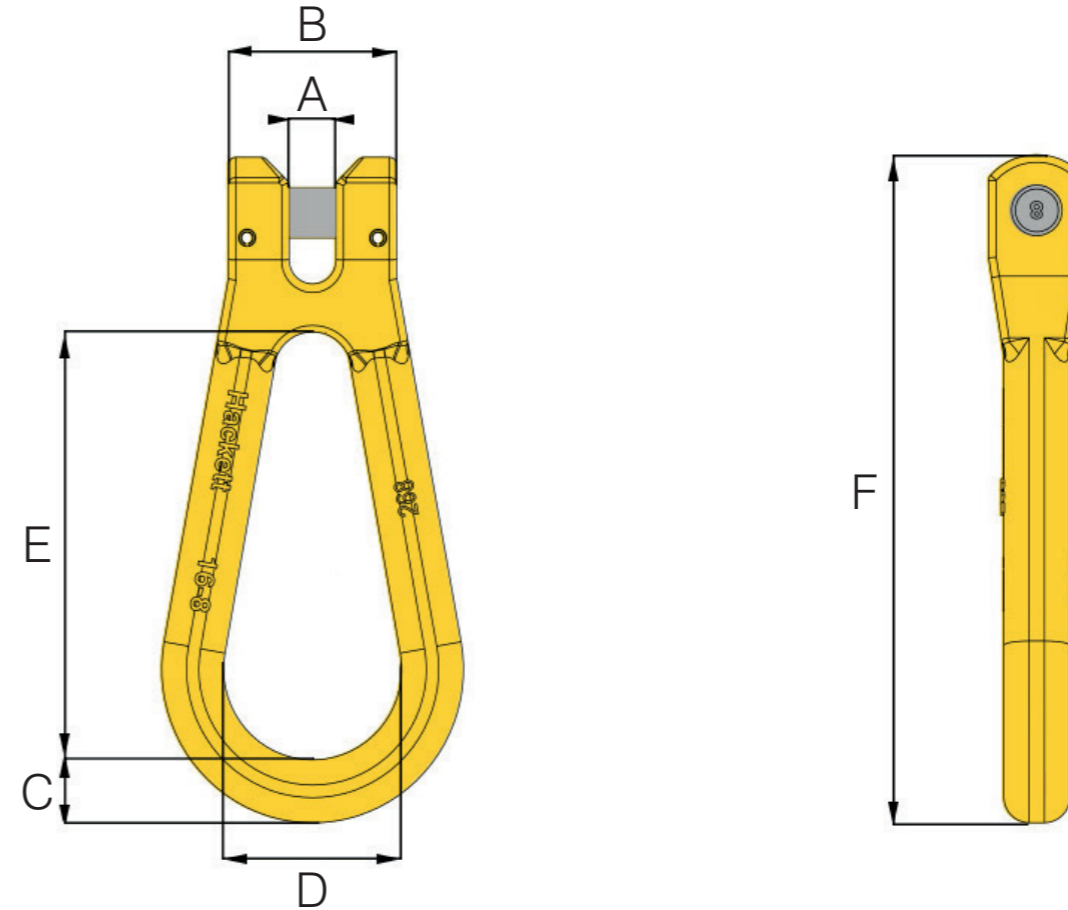

### Specifications

Part Code	Chain Size mm	A mm	B mm	C mm	D mm	E mm	F mm	Box Qty.	WLL tonnes	Mass kg
8-H07-08	7/8	9.0	32.8	15.0	45.0	105.5	139.0	35	2.00	0.53
8-H07-10	10	12.0	42.0	19.0	60.0	130.0	174.0	20	3.15	0.74
8-H07-13	13	15.0	58.0	22.0	66.5	177.0	226.0	10	5.30	1.76
8-H07-16	16	19.0	68.0	26.0	72.0	202.0	264.0	6	8.00	2.80

## Hack8 Reeveable Egg Link

The Hack8 reeveable egg link is specifically designed for use in Hackett grade 8 collar slings. The wide link aperture allows another reeveable egg link to pass through, creating a chokage lift. This link is capable of attachment directly onto chain thanks to its clevis attachment type. Manufactured from alloy steel, the Hack8 reeveable egg link delivers an excellent balance between toughness and ductility.

**Standards:** designed and manufactured in accordance with EN1677-1 and suitable for use in chain slings certified to EN818-4.

**Product sizes:** available for chain sizes from 9/32 - 5/16 inch to 5/8 inch and with working load limits from 4,500 lbs to 18,100 lbs.

**Temperature:** operational temperature range of -40°F to +392°F (-40°C to + 200°C) without reduction in working load limit.

**Material:** alloy steel.

**Testing:** crack detection following heat treatment, and proof load tested to 2.5 times working load limit.

**Safety factor:** 4 : 1.

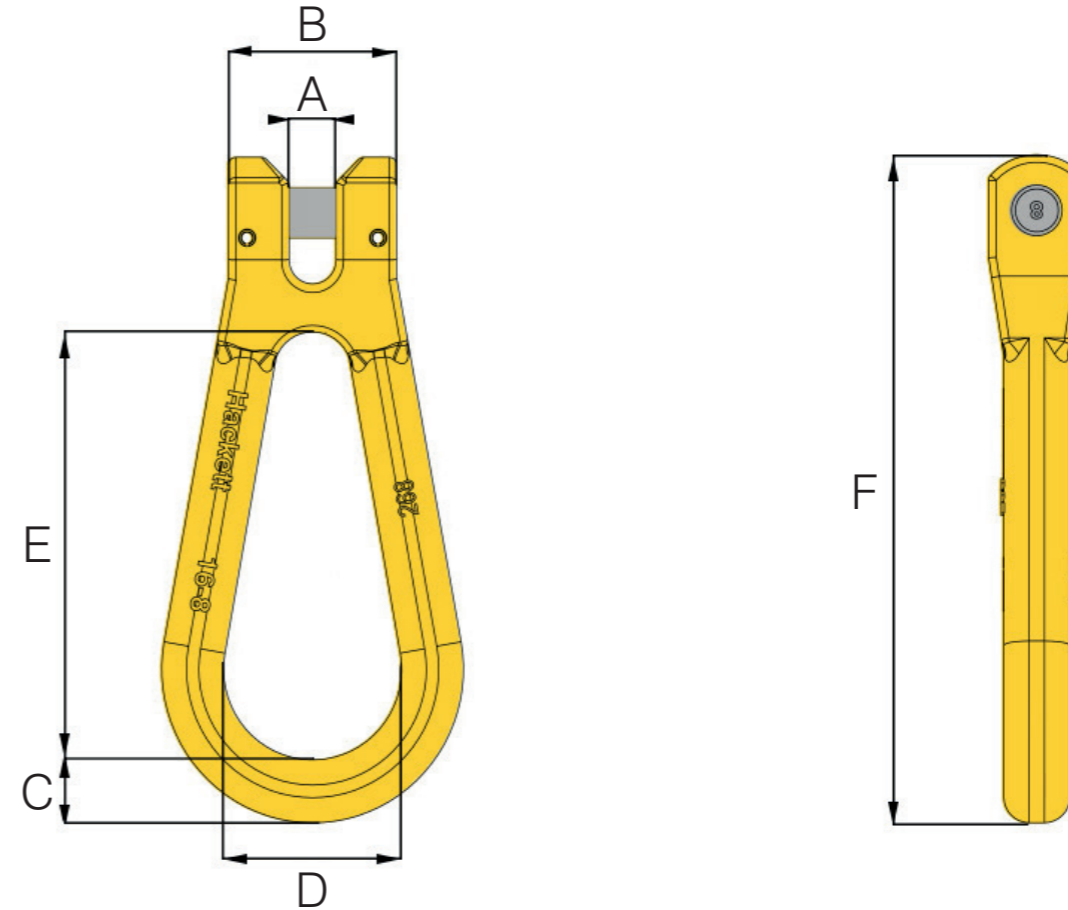

### Specifications

Part Code	Chain Size inch	A inch	B inch	C inch	D inch	E inch	F inch	Box Qty.	WLL lbs	Mass lbs
8-H07-08	9/32 - 5/16	0.35	1.29	0.59	1.77	4.15	5.47	35	4500	1.17
8-H07-10	3/8	0.47	1.65	0.75	2.36	5.12	6.85	20	7100	1.63
8-H07-13	1/2	0.59	2.28	0.87	2.62	6.97	8.90	10	12000	3.88
8-H07-16	5/8	0.75	2.68	1.02	2.83	7.95	10.39	6	18100	6.17