

Hack8 Weld On 'D' Ring

All William Hackett Grade 8 lifting components comply fully with the relevant section of EN1677, they are forged from alloy steel, they are crack detected following heat treatment and finally proof tested to 2.5 times working load. The full compliance of these components means that they can be used in chain slings certified to EN 818-4, for use in a temperature range of -40°C up to 200°C without reduction in working load limit.

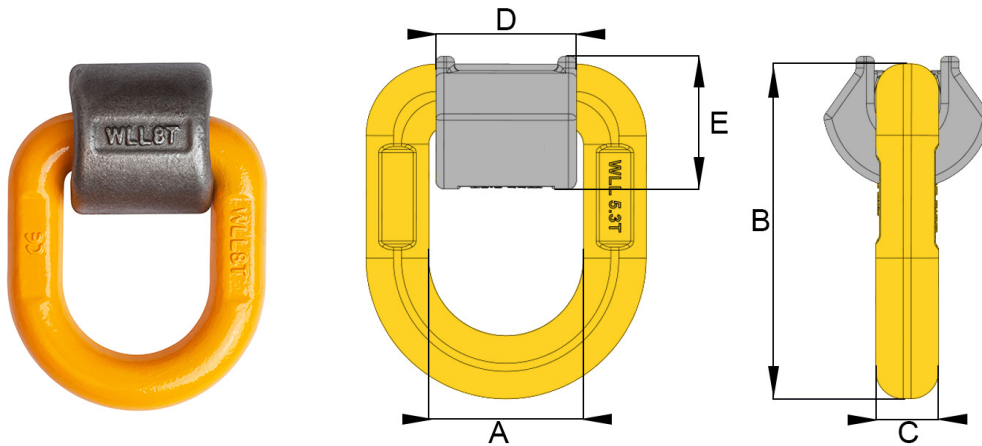

Metric Specifications

Part Code	A mm	B mm	C mm	D mm	E mm	Box Qty.	WLL tonnes	Mass kg
8-H08-001	41	78.5	13.0	37.0	33.5	50	1.12	0.40
8-H08-003	45	94.0	17.0	45.0	39.0	30	3.15	0.70
8-H08-005	55	118.0	22.0	50.0	49.0	15	5.30	1.50
8-H08-008	70	141.0	26.5	70.0	54.0	10	8.00	2.50

Imperial Specifications

Part Code	A inch	B inch	C inch	D inch	E inch	Box Qty.	WLL lbs	Mass lbs
8-H08-001	1.61	3.09	0.51	1.45	1.31	50	2469	0.88
8-H08-003	1.77	3.70	0.66	1.77	1.53	30	7100	1.54
8-H08-005	2.16	4.64	0.86	2.40	1.92	15	12000	3.30
8-H08-008	2.75	5.55	1.04	2.75	2.12	10	18100	5.51