

Hack8 Clevis Shackle

All William Hackett Grade 8 lifting components comply fully with the relevant section of EN1677, they are forged from alloy steel, they are crack detected following heat treatment and finally proof tested to 2.5 times working load. The full compliance of these components means that they can be used in chain slings certified to EN 818-4, for use in a temperature range of -40°C up to 200°C without reduction in working load limit.

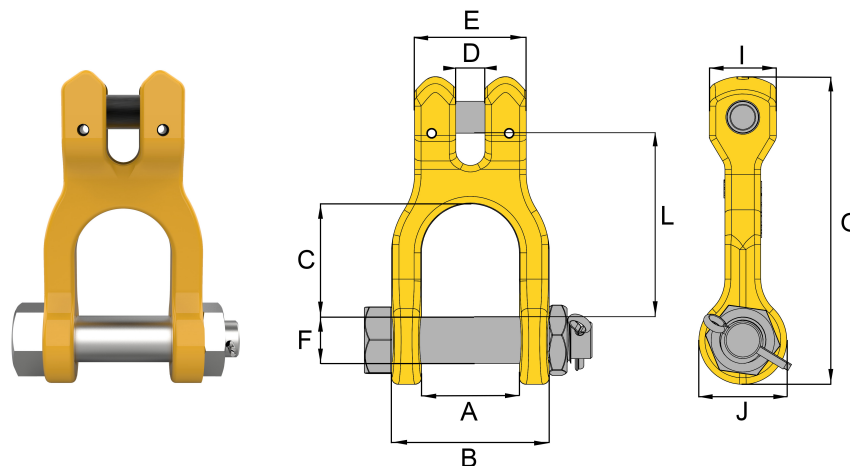

METRIC SPECIFICATIONS

Part Code	Chain Size mm	A mm	B mm	C mm	D mm	E mm	F mm	G mm	I mm	J mm	L mm	WLL tonnes	Box Quantity	Mass kg
8-H16-08	7/8	31.0	51.0	36.3	9.0	36.0	16.0	103.5	20.0	34.0	61.0	2.00	35	0.40
8-H16-10	10	34.0	62.0	48.0	12.5	46.5	20.0	130.7	25.0	40.0	78.5	3.15	20	0.89
8-H16-13	13	49.0	83.0	64.0	15.0	59.0	22.0	160.0	31.0	44.0	98.5	5.30	18	1.51
8-H16-16	16	58.0	95.0	69.5	19.0	70.0	28.5	190.5	40.0	55.0	114.0	8.00	10	2.62

IMPERIAL SPECIFICATIONS

Part Code	Chain Size inch	A inch	B inch	C inch	D inch	E inch	F inch	G inch	I inch	J inch	L inch	WLL lbs	Box Quantity	Mass lbs
8-H16-08	1/4 - 5/16	1.22	2.01	1.43	0.35	1.42	0.63	4.07	0.79	1.34	2.40	4500	35	0.88
8-H16-10	3/8	1.34	2.44	1.89	0.49	1.83	0.79	5.15	0.98	1.57	3.09	7100	20	1.96
8-H16-13	1/2	1.93	3.27	2.52	0.59	2.32	0.87	6.30	1.22	1.73	3.88	12000	18	3.32
8-H16-16	5/8	2.28	3.74	2.74	0.75	2.75	1.12	7.50	1.57	2.17	4.49	18100	10	5.77