

CX Hinged vertical plate clamps

Heavy duty - side loading

Working load limit (WLL) 150 - 10000 kg

The CX plate clamps share all the benefits of the CY clamps but are specifically designed for more heavy duty applications.

The other benefit that the CX clamp offers over the CY is that vertically racked plates can be turned through 90°.

Workmanship and parts

These plate clamps are service-friendly, making it easy to exchange parts, which are readily available. Clamp repairs must be done by a trained person.

Product group: I2

INFO

The plate surface of the material being clamped must have a hardness level below HRC 30/Brinell 300.

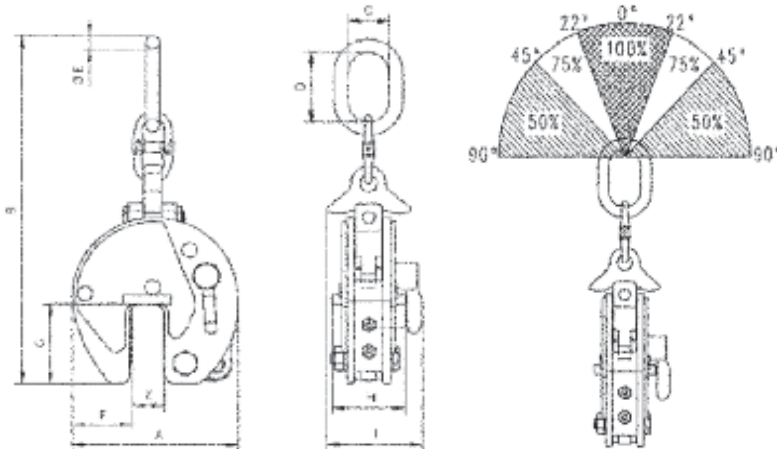

Technical data CX

Model	Art.-No.	*WLL kg	Jaw (Z) Capacity mm	A mm	B mm	C mm	D mm	E mm	F mm	G mm	H mm	I mm	*Weight kg
CX1500	N430000080	150 - 1500	0 - 20	140	399	63	125	12.5	48	70	57	83	7
CX3000	N430000082	300 - 3000	0 - 32	197	515	67	138	19	68	93	81	110	12
CX3000L	N430000083	300 - 3000	30 - 60	227	515	67	138	19	68	93	81	110	15
CX6000	N50200305	600 - 6000	0 - 50	292	737	95	176	28	95	143	137	188	38
CX6000L	N50200306	600 - 6000	50 - 100	367	785	98	180	28	115	143	135	188	48
CX8000	N50200307	800 - 8000	0 - 50	292	737	98	176	28	95	143	136	210	39
CX8000L	N50200310	800 - 8000	50 - 100	367	785	98	180	28	115	143	136	210	51
CX10000	N50200308	1000 - 10000	0 - 50	360	903	110	195	33	125	162	170	223	61
CX10000L	N50200311	1000 - 10000	50 - 100	446	921	112	195	33	168	162	170	223	76

*Per clamp